

AMT-A0010 100MHz to 2000MHz Ultra Flat Gain with High Linearity Amplifier

Data Sheet



Features

- Ultra Flat Gain $\pm 0.15\text{ dB}$ from 300 to 2000MHz Frequency Range
- Gain 15 dB
- High Linearity, OIP3 > +36 dBm
- 2 dB Noise Figure
- High Efficiency, 300mW (5V,65mA)
- +19 dBm Output Power at 1 dB gain compression point
- Temperature Compensated to maintain steady Gain
- Operates from a Single +8V Supply
- Excellent Unit-to-Unit Phase and Gain Matching

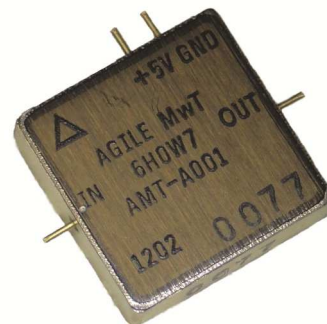

Description

The AMT-A0010 is a broadband, ultra flat gain, high linearity, temperature compensated amplifier achieved through the use of AMTI's proprietary technology. The amplifier I/Os are Internally matched to 50 Ohms and are DC blocked. The AMT-A0010 is ideal for use as gain block, Input stage or driver stage in a Hi-Rel communications system for Commercial or Military applications

Applications

- IF Amplifier, Input Amplifier
- RF Driver amplifier
- General purpose gain block

Functional Diagram

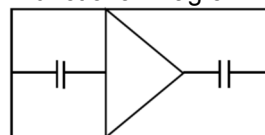

MAXIMUM RATINGS¹

Parameter	Symbol	Units	MIN	MAX
Operating Temperature – Case	T_{MO}	$^{\circ}\text{C}$	-40	+85
Storage Temperature - Case	T_{MS}	$^{\circ}\text{C}$	-55	+150
RF Input power (CW)	P_{in}	dBm		+20
Die $T_{Junction}$	T_J	$^{\circ}\text{C}$		+150
Thermal Resistance	Θ_{jc}	$^{\circ}\text{C/Watt}$		+76
ESD	V	<math><400^2</math>		
Positive Supply Voltage	V_{+SS}	V		+9

1. Stresses above those listed under "Absolute Maximum Rating" may cause permanent damage to the device. This is a stress rating only and functional operation of the device at these or any other conditions above those indicated in the operational sections of this specification is not implied. Exposure to absolute maximum rating conditions for extended periods may affect device reliability.

2. ESD Human Body Model =400V, ESD machine model = 50V

ELECTRICAL SPECIFICATIONS @ 23°C

Parameter	Conditions	Units	MIN	Typical	MAX
Frequency Range		MHz	300		2000
Gain	Small Signal	dB	14	15	
Gain Flatness		dB		±0.15	±0.2
Output Power	1 dB compression point @ 1GHz	dBm	+18.5	+19.5	
OIP3	Two Tone F1—F2 = 10MHz @ 1 GHz	dBm		+36	
Amplitude Matching ²	For matched units only	dB		±0.15	
Amplitude Tracking ²	For matched units only	dB		±0.15	
Phase Matching ²	For matched units only	deg		±2	
Phase Tracking ²	For matched units only	deg		±1	
Noise Figure		dB		2.0	2.4
RF Input Impedance	Reference to 50 ohms			1.5:1	2.0:1
RF Output Impedance	Reference to 50 ohms			1.8:1	2.0:1
Supply Voltage Positive:	(+5V option without Internal Regulator)	V		+5V +8V	
Supply Current Positive:		mA		65	90

Pin Numbers	Function
1	RF Input
2	+5V
3	Ground
4	RF Output
Case	Ground
RFin and RFout pins have internal DC blocking capacitor	

Model Number	Description	Package
AMT-A001-FP	4 pin Flat Pack	FP 0.500SQ, 0.170Ht AMT-M001
AMT-A001-SMA	SMA Connectorized	Outline: M088

Package Outline: Flat Pack 0.500SQ (inches)

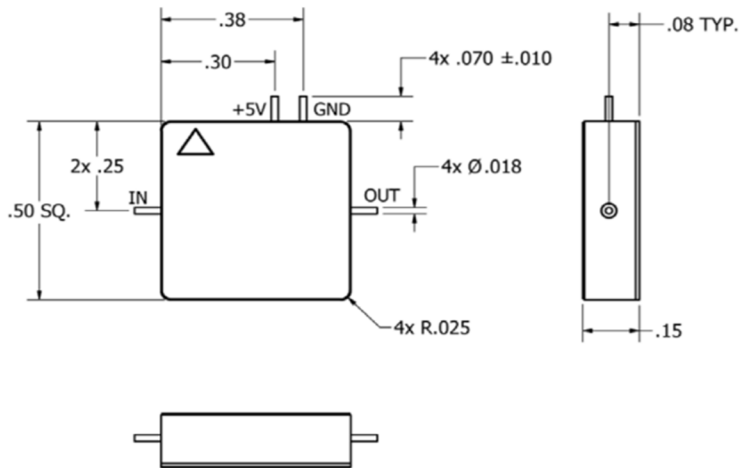

PIN	FUNCTION	PIN	FUNCTION
1	RFIN	3	GND
2	+5V	4	RFOUT
CASE = GND			

Package Outline: SMA Connectorized (inches)

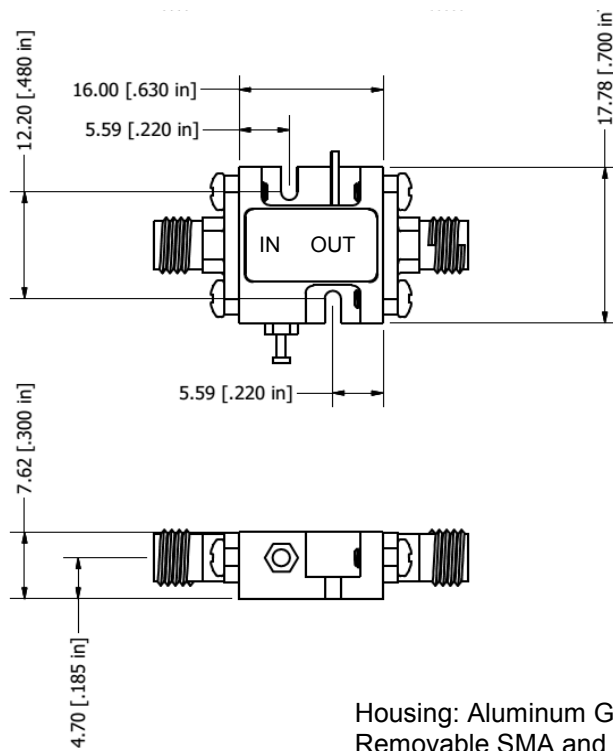

Contact us for custom configurations and special requirements.

Our highly experienced team of engineers can quickly identify and implement innovative solutions using latest technology to improve performance and reduce cost.

- Add additional functionality: Input limiter, Temperature compensation, Amplitude/Phase matching, Amplitude/Phase Tracking, Automatic Gain control, Gain sloping, Bypass path, Specific supply voltage, Regulation, Power detector, Health status, and others
- Integrated: Filters, Switches, Limiter, Digital attenuator, Phase shifter, Microcontroller, Multiple amplifiers, Switch matrix, Comb generators and others
- Mechanical: Custom packages - Surface Mount, Connectorized, Waveguide, Carrier, Drop-in, Hermetic and others

Agile Microwave Technology Inc is the logical choice for all your commercial or military RF/Microwave components/module requirements.

Contact Information:

**701 Cascade Pointe Lane
Cary, NC 27513**

**ISO 9001:2015
Certified Company**

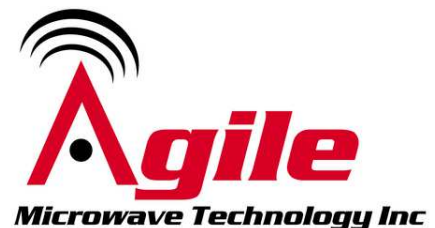

Phone: (984) 228-8001

info@agilemwt.com

www.agilemwt.com

AMTI reserves the right to change at any time without notice the design, specifications, function/form or availability of its products described herein. The buyer/customer has the responsibility to validate the performance for their applications. No liability is assumed as result of use of this product and no patent licenses are implied. AMTI reserves all rights.