

AMT-A0290 27 GHz to 30 GHz Ka Band Medium Power Amplifier

Data Sheet



Features

- 27 GHz to 30 GHz Frequency Range
- Typical P1dB power > +25 dBm
- Gain dB Typical 36 dB
- Gain Flatness ± 1 dB Typical
- VSWR 1.4:1 typical
- Internally Regulated
- Operates from Single +8 Supply 370mA
- Unconditionally Stable
- Compact Housing



Description

The AMT-A0290 is a +25 dBm P1dB Broadband medium power amplifier with high efficiency in a compact size. The performance is achieved through the use of AMTI's proprietary matching technology and latest in GaAs technology. The amplifier I/Os are Internally matched to 50 Ohms and DC Blocked. The AMT-A0290 is ideal for use as medium power amplifier for test equipment, Communication systems or where broadband amplification and power are required good efficiency in a Hi-Rel communications system for Commercial or Military applications

Applications

- Test Equipment
- RADAR Applications
- Lab Applications
- Point to Point Communications

MAXIMUM RATINGS¹

EAR99

Parameter	Symbol	Units	MIN	MAX
Operating Temperature – Case	T_{MO}	$^{\circ}C$	-20	+75
Storage Temperature - Case	T_{MS}	$^{\circ}C$	-40	+125
RF Input power (CW)	P_{in}	dBm		+0
Die $T_{Junction}$	T_J	$^{\circ}C$		+150
Positive Supply Voltage	V_{+SS}	V		+10

Appropriate Heat sink must be used

1.Stresses above those listed under "Absolute Maximum Rating" may cause permanent damage to the device. This is a stress rating only and functional operation of the device at these or any other conditions above those indicated in the operational sections of this specification is not implied. Exposure to absolute maximum rating conditions for extended periods may affect device reliability.

ELECTRICAL SPECIFICATIONS @ 25°C

Parameter	Conditions	Units	MIN	Typical	MAX
Frequency Range		GHz	27		30
Gain	Small Signal	dB	34	36	
Gain Flatness		dB		±1	±1.8
Output Power (P1dB)	1 dB compression	dBm	23	25	
OIP3	@ 26GHz 2 Tone	dB		31	
RF Input Impedance	Reference to 50 ohms VSWR			1.4:1	2.0:1
RF Output Impedance	Reference to 50 ohms VSWR			1.4:1	2.0:1
Supply Voltage Positive:		V		+8V	
Supply Current Positive:		mA		370	600

Notes:

1/ Unconditional Stability

Customized configurations of the above specifications are available

Package Outline M084: 2.92mm Connectorized mm(inches)

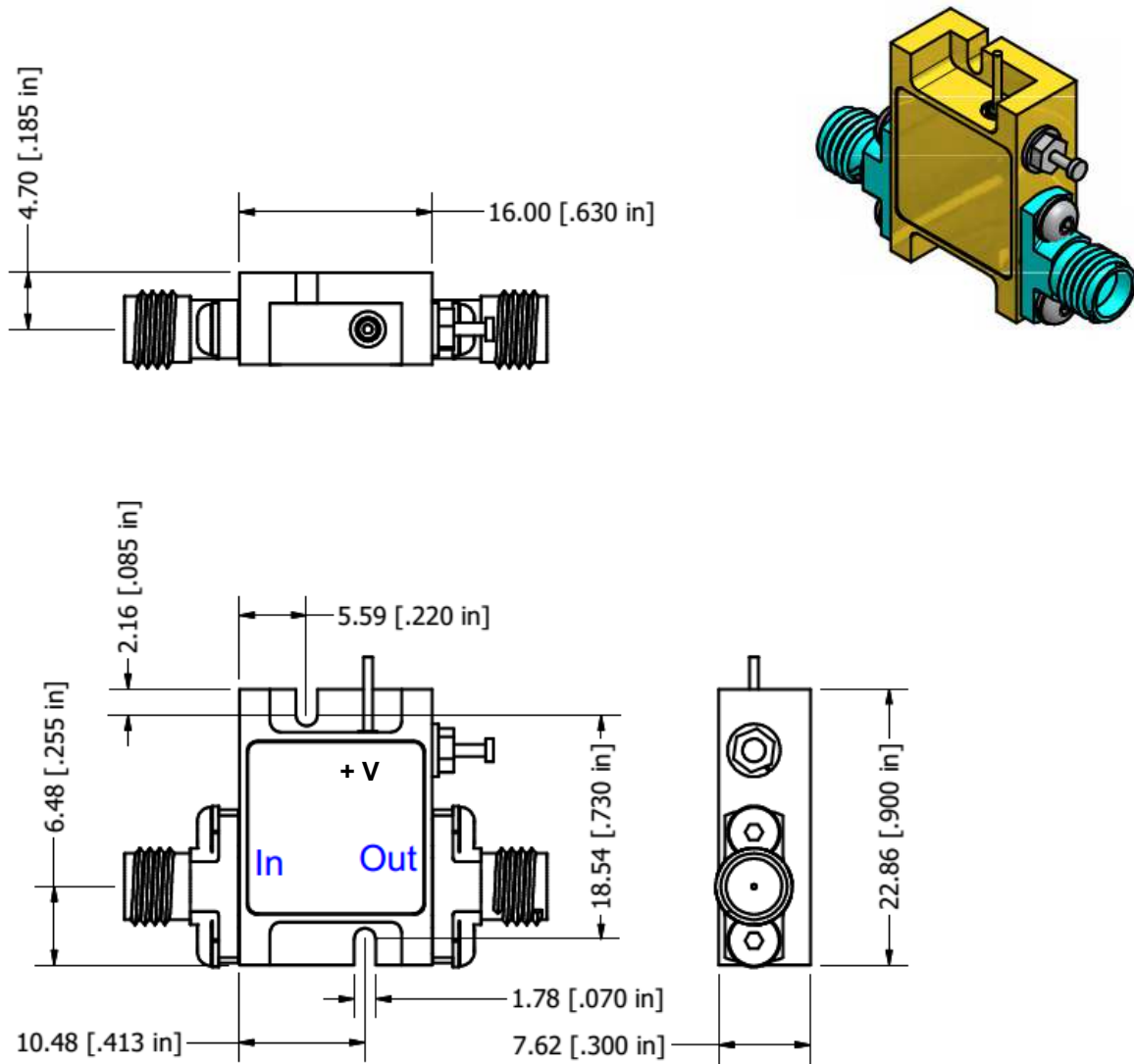

Field replaceable SMA Connectors, Removable Ground Slug

Note: The unit must be attached to proper heat sink

Model Number	Description	Hermeticity	Package
AMT-A0290	2.92 mm Female	Non-Hermetic	Outline: M084

Contact us for custom configurations and special requirements.

Our highly experienced team of engineers can quickly identify and implement innovative solutions using latest technology to improve performance and reduce cost.

- Add additional functionality: Input limiter, Temperature compensation, Amplitude/Phase matching, Amplitude/Phase Tracking, Automatic Gain control, Gain sloping, Bypass path, Specific supply voltage, Regulation, Power detector, Health status, and others
- Integrated: Filters, Switches, Limiter, Digital attenuator, Phase shifter, Microcontroller, Multiple amplifiers, Switch matrix, Comb generators and others
- Mechanical: Custom packages - Surface Mount, Connectorized, Waveguide, Carrier, Drop-in, Hermetic and others

Agile Microwave Technology Inc is the logical choice for all your commercial or military RF/Microwave components/module requirements.

Contact Information:

**701 Cascade Pointe Lane
Cary, NC 27513**

**ISO 9001:2015
Certified Company**

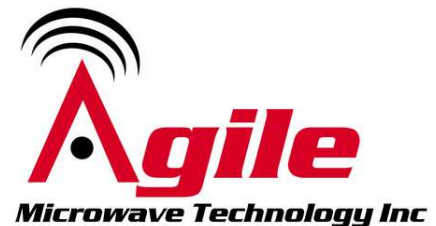

Phone: (984) 228-8001

info@agilemwt.com

www.agilemwt.com

AMTI reserves the right to change at any time without notice the design, specifications, function/form or availability of its products described herein. The buyer/customer has the responsibility to validate the performance for their applications. No liability is assumed as result of use of this product and no patent licenses are implied. AMTI reserves all rights .