

# AMT-A0091 0.01 GHz to 6 GHz Broadband Low Noise Medium Power Amplifier

## Data Sheet



## Features

- 0.01 GHz to 6 GHz Frequency Range
- Typical Noise Figure < 1.2 dB
- Typical Gain 45 dB
- Gain Flatness <  $\pm 1.2$  dB
- +20 dBm P1dB
- Internally Regulated
- Operates from a +12 V Single Supply
- Unconditionally Stable
- State-of-the-Art GaAs Technology

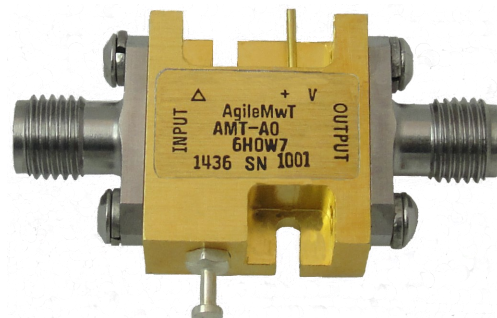

## Description

The AMT-A0091 is a Broadband Low Noise medium power amplifier with very low noise figure and Pout of + 20 dBm over the full frequency range. The performance is achieved through the use of AMTI's proprietary technology. The amplifier I/Os are Internally matched to 50 Ohms. The AMT-A0091 is ideal for use as Front End of receiver system, or where amplification is required without adding excessive noise in a Hi-Rel communications system for Commercial or Military applications

## Applications

- Receiver front end
- Radar
- Communication systems
- Microwave Radio systems
- Test Equipment

## MAXIMUM RATINGS<sup>1</sup>

Parameter	Symbol	Units	MIN	MAX
Operating Temperature – Case	T <sub>MO</sub>	° C	-40	+85
Storage Temperature - Case	T <sub>MS</sub>	° C	-54	+150
RF Input power (CW)	P <sub>in</sub>	dBm		+10
Die T <sub>Junction</sub>	T <sub>J</sub>	° C		+150
Positive Supply Voltage	V <sub>+SS</sub>	V		+15.5

Note: Do not apply DC to RF Input

1. Stresses above those listed under "Absolute Maximum Rating" may cause permanent damage to the device. This is a stress rating only and functional operation of the device at these or any other conditions above those indicated in the operational sections of this specification is not implied. Exposure to absolute maximum rating conditions for extended periods may affect device reliability.

## ELECTRICAL SPECIFICATIONS @ 23°C

Parameter	Conditions	Units	MIN	Typical	MAX
Frequency Range		GHz	0.01		6
Gain	Small Signal	dB	38	45	
Gain Flatness <sup>2</sup>		dB		±1.2	±2.0
Input Power	CW, without damage	dBm	+10		
Output Power (P1dB)	1 dB compression point @ 3 GHz	dBm	+20		
OIP3	OPI3 measured @ 3 GHz Two tone F1-F2= 10MHz	dB		30	
Noise Figure <sup>2</sup>		dB		1.2	2.2
RF Input Impedance <sup>2</sup>	Reference to 50 ohms VSWR			1.8:1	2.3:1
RF Output Impedance <sup>2</sup>	Reference to 50 ohms			1:7:1	2.3:1
Supply Voltage Positive:		V		+12	
Supply Current Positive:		mA		190	280

Notes:

1/ Unconditional Stability: ( $K > 1$ ) and ( $B1 > 0$ )

2/ Maybe higher below 300 MHz and NF higher below 500 MHz

Customized configurations of the above specifications are available

# Typical S-Parameters @ 23C

## S-Par from 30kHz to 2000 MHz

CH1 LOG 10 dB/ REF 0 dB  
S11 5: -13.567 dB 1 999.600 006 MHz

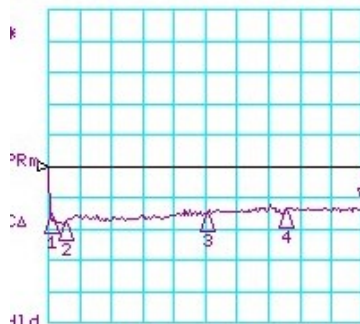

CH1 Markers  
1: -15.811 dB  
10.0000 MHz  
2: -17.920 dB  
100.000 MHz  
3: -14.993 dB  
1.00000 GHz  
4: -13.956 dB  
1.50000 GHz

START .030 MHz STOP 2000.000 MHz

CH3 LOG 10 dB/ REF -10 dB  
S12 5: -56.631 dB 1 999.600 006 MHz

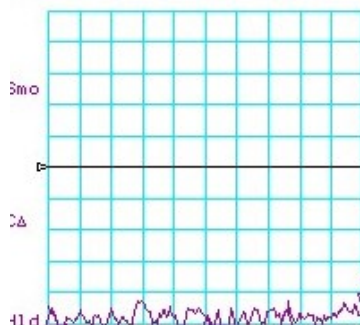

CH3 Markers  
1: -55.399 dB  
10.0000 MHz  
2: -62.980 dB  
100.000 MHz  
3: -57.658 dB  
1.00000 GHz  
4: -55.903 dB  
1.50000 GHz

START .030 MHz STOP 2000.000 MHz

CH2 LOG 10 dB/ REF 0 dB  
S21 5: 46.355 dB 1 999.600 006 MHz

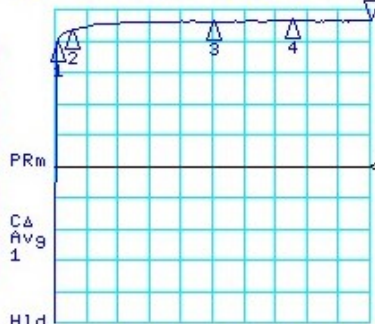

CH2 Markers  
1: 39.441 dB  
10.0000 MHz  
2: 43.448 dB  
100.000 MHz  
3: 46.228 dB  
1.00000 GHz  
4: 46.431 dB  
1.50000 GHz

START .030 MHz STOP 2000.000 MHz

CH4 LOG 10 dB/ REF 0 dB  
S22 5: -12.205 dB 1 999.600 006 MHz

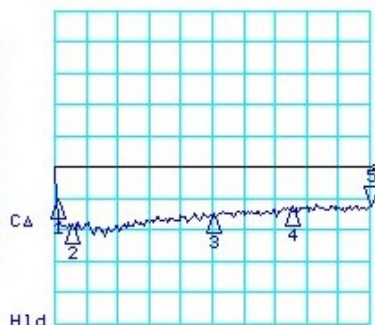

CH4 Markers  
1: -10.686 dB  
10.0000 MHz  
2: -18.416 dB  
100.000 MHz  
3: -15.322 dB  
1.00000 GHz  
4: -12.818 dB  
1.50000 GHz

START .030 MHz STOP 2000.000 MHz

## S-Par from 2 GHz to 10 GHz

CH1 LOG 10 dB/ REF 0 dB  
S11 5: -12.196 dB 6.000 000 000 GHz

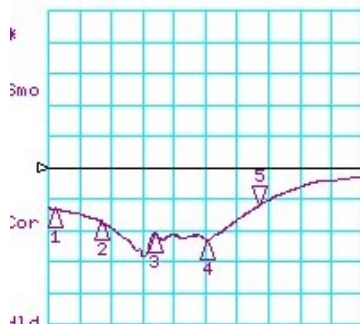

CH1 Markers  
1: -13.469 dB  
2.10000 GHz  
2: -17.262 dB  
3.00000 GHz  
3: -21.275 dB  
4.00000 GHz  
4: -23.441 dB  
5.00000 GHz

START 2000.000 MHz STOP 8000.000 MHz

CH3 LOG 10 dB/ REF -10 dB  
S12 5: -55.383 dB 6.000 000 000 GHz

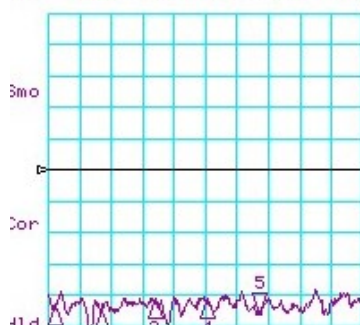

CH3 Markers  
1: -53.994 dB  
2.10000 GHz  
2: -55.231 dB  
3.00000 GHz  
3: -51.712 dB  
4.00000 GHz  
4: -51.404 dB  
5.00000 GHz

START 2000.000 MHz STOP 8000.000 MHz

CH2 LOG 10 dB/ REF 0 dB  
S21 5: 44.467 dB 6.000 000 000 GHz

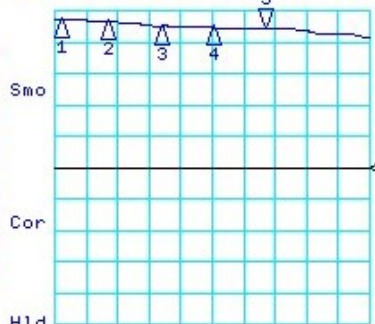

CH2 Markers  
1: 47.492 dB  
2.10000 GHz  
2: 46.597 dB  
3.00000 GHz  
3: 45.168 dB  
4.00000 GHz  
4: 44.747 dB  
5.00000 GHz

START 2000.000 MHz STOP 8000.000 MHz

CH4 LOG 10 dB/ REF 0 dB  
S22 5: -9.150 dB 6.000 000 000 GHz

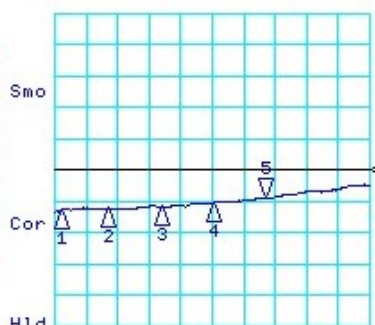

CH4 Markers  
1: -12.785 dB  
2.10000 GHz  
2: -12.330 dB  
3.00000 GHz  
3: -11.643 dB  
4.00000 GHz  
4: -10.428 dB  
5.00000 GHz

START 2000.000 MHz STOP 8000.000 MHz

# Typical Noise Figure @ 23C

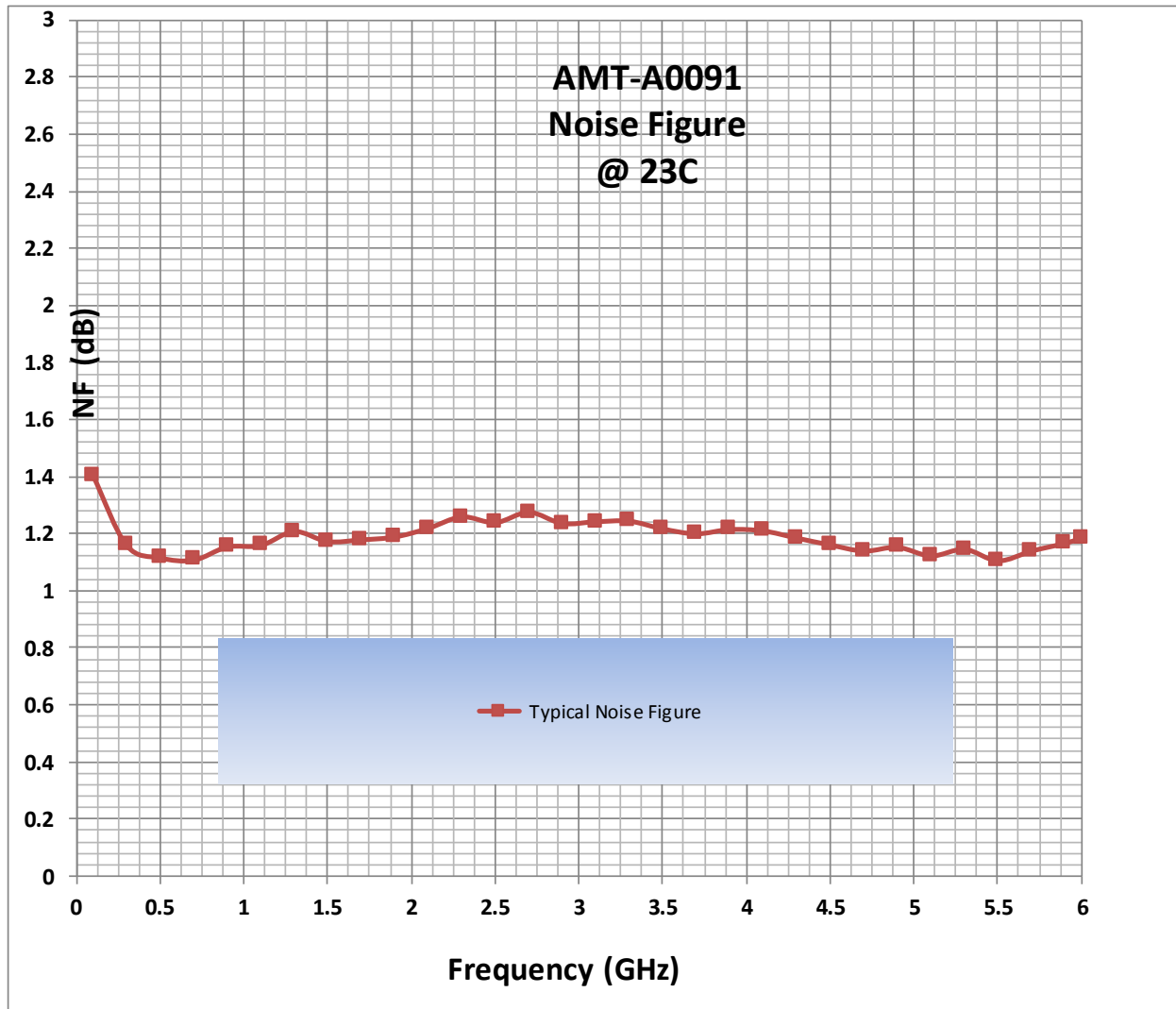

## Package Outline: M110 SMA Connectorized (inches)

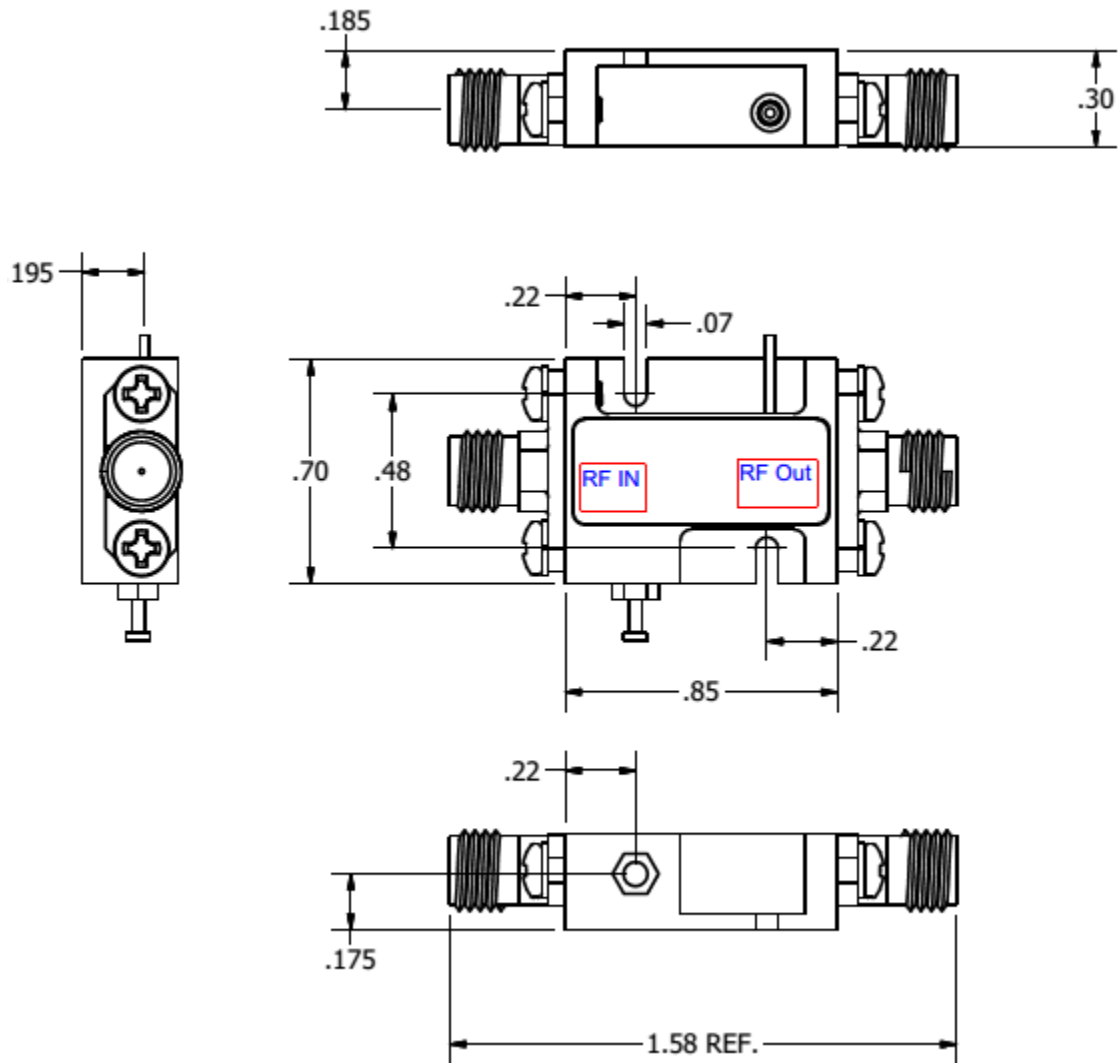

**SMA and Ground Slug are removable  
Amplifier requires proper heat sink**

<b>Model Number</b>	<b>Description</b>	<b>Hermeticity</b>	<b>Package</b>
AMT-A0091	SMA Female	Non-Hermetic	Outline: M088
AMT-A0091-H	SMA Female	Hermetic	Outline:

Contact us for custom configurations and special requirements.

Our highly experienced team of engineers can quickly identify and implement innovative solutions using latest technology to improve performance and reduce cost.

- Add additional functionality: Input limiter, Temperature compensation, Amplitude/Phase matching, Amplitude/Phase Tracking, Automatic Gain control, Gain sloping, Bypass path, Specific supply voltage, Regulation, Power detector, Health status, and others
- Integrated: Filters, Switches, Limiter, Digital attenuator, Phase shifter, Microcontroller, Multiple amplifiers, Switch matrix, Comb generators and others
- Mechanical: Custom packages - Surface Mount, Connectorized, Waveguide, Carrier, Drop-in, Hermetic and others

Agile Microwave Technology Inc is the logical choice for all your commercial or military RF/Microwave components/module requirements.

## Contact Information:

**101 Bloomingdale Road  
Hicksville, NY 11801**

**Phone: (516) 931-1760**

**Fax: (212) 374-1153**

**[info@agilemwt.com](mailto:info@agilemwt.com)**

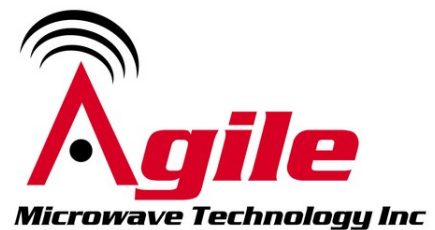

**[www.agilemwt.com](http://www.agilemwt.com)**

AMTI reserves the right to change at any time without notice the design, specifications, function/form or availability of its products described herein. The buyer/customer has the responsibility to validate the performance for their applications. No liability is assumed as result of use of this product and no patent licenses are implied. AMTI reserves all rights.